

Kelvion

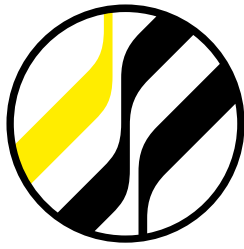

COUNTERFLOW COOLING TOWERS

POLACEL CMDI SERIES

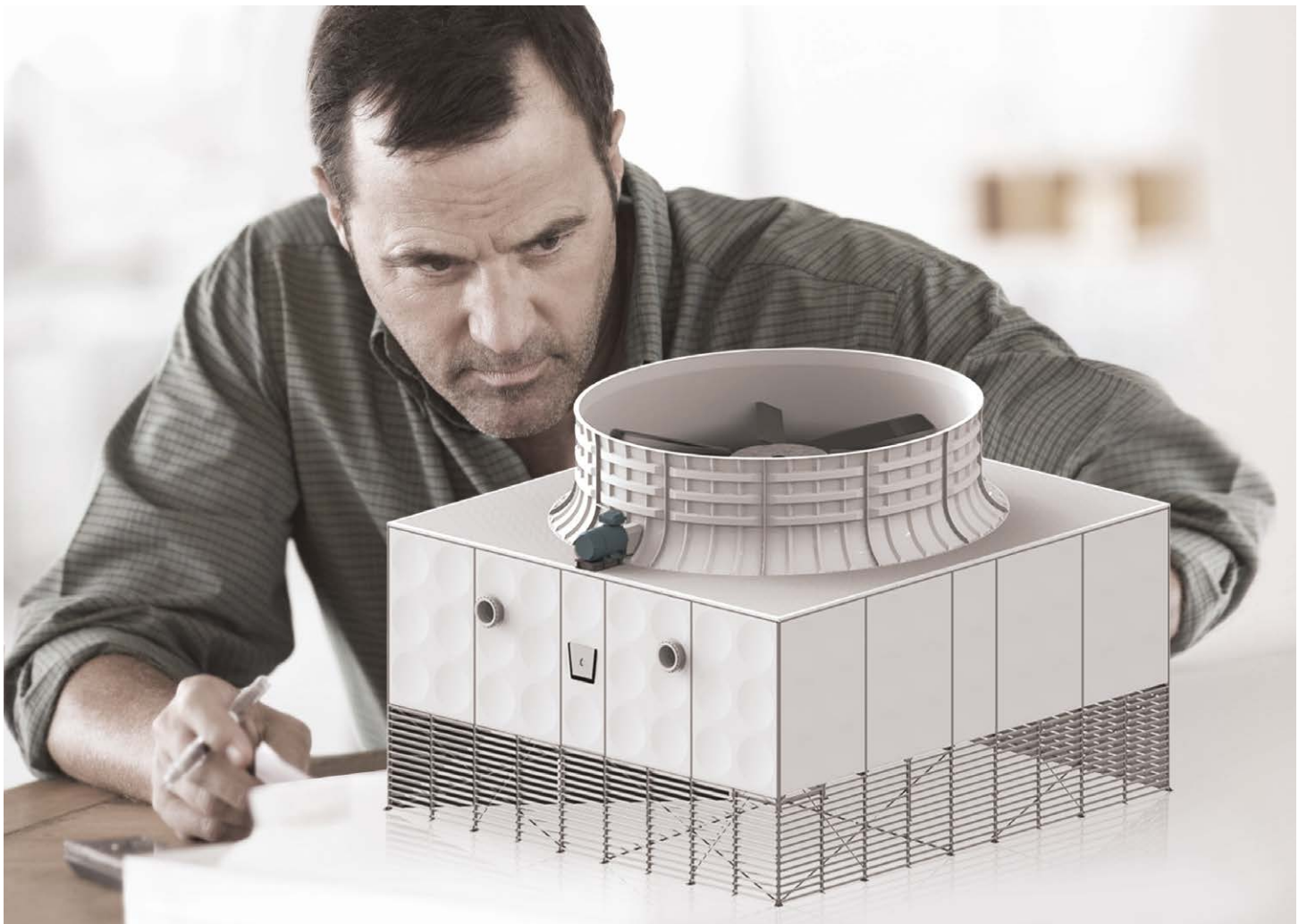

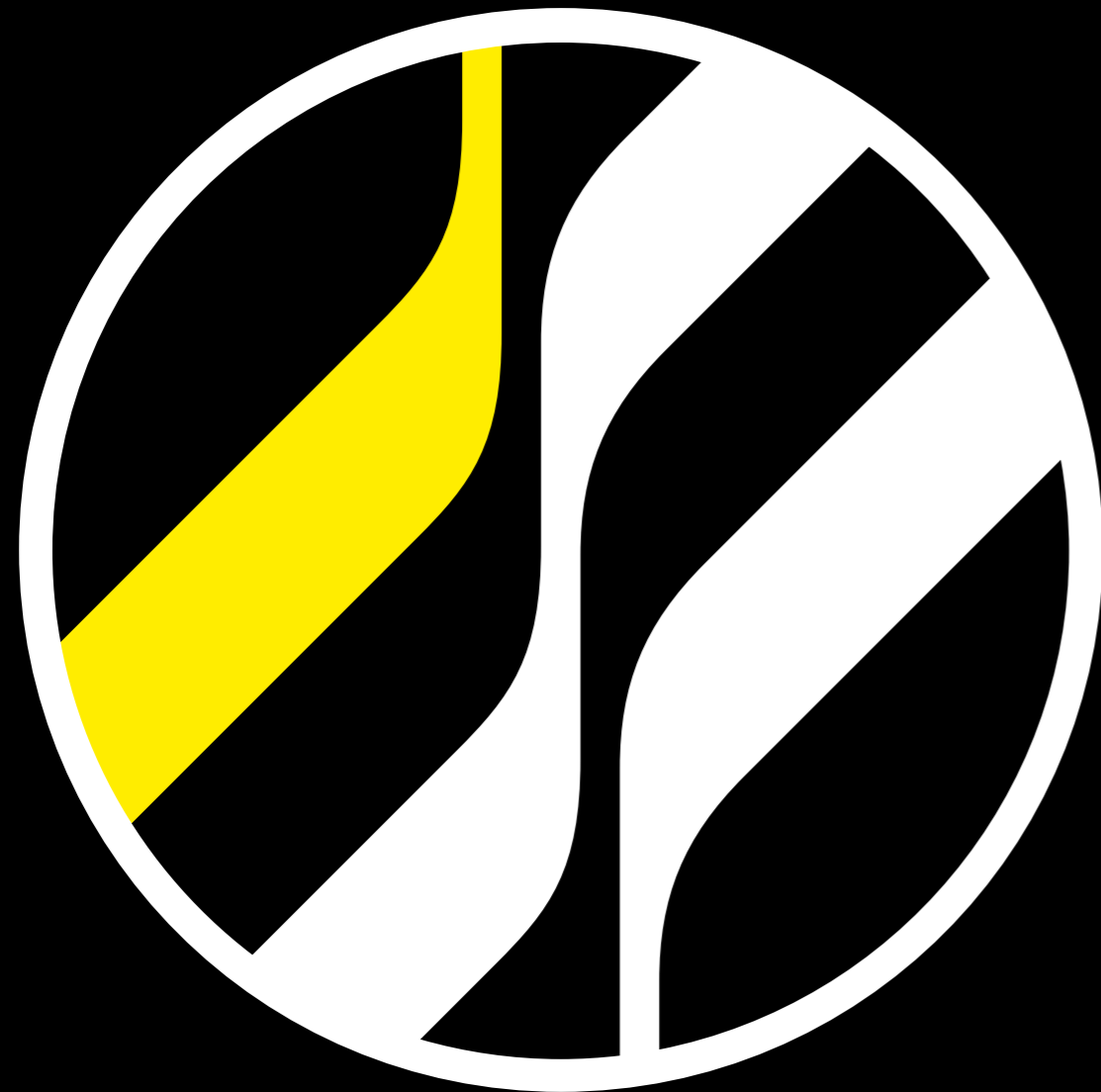

WE ARE KELVION – THE NEW BRAND IN HEAT EXCHANGE

GEA Heat Exchangers has changed: another new standalone company has been created out of the former Heat Exchanger Division of the GEA Group AG. The name Kelvion is new, but we continue as global experts in heat exchange. As always, we remain committed to earning your trust.

You'll still recognize us. We continue to develop our products, manufacture them with precision and distribute globally. We continue to offer one of the world's largest heat exchanger product portfolios: Plate heat exchangers, shell & tube heat exchangers, finned tube heat exchangers, modular cooling towers and refrigeration heat exchangers for a wide range of applications.

We operate in global markets for power generation, oil and gas, chemistry, marine applications, climate and environment, and food and beverages. From us, you can expect products with outstanding levels of efficiency, safety, and sustainability. More importantly, we care about your business, like close, trusted partners.

Customers rely on us to understand their needs, boost their performance, and deliver products that always get the job done. We compete for the toughest deals, in the harshest environments. But we're not too big to care. We're Kelvion – ready to take on the challenges of heat exchange. www.kelvion.com

Experts in Heat Exchange.

CUSTOM-MADE OUT OF STANDARD COMPONENTS



Characteristics:

- Over 40 years of experience in the development, design, production, installation and maintenance of cooling towers
- Modular products available for all popular sizes
- Extreme durability through the usage high quality materials like stainless steel, glass fiber reinforced plastics and thermoplastics like polypropylene
- Over 500 models in both counter and cross flow certified in the thermal rating program of the Cooling Technology Institute (CTI)
- Customizable to your demands by our own sales engineers

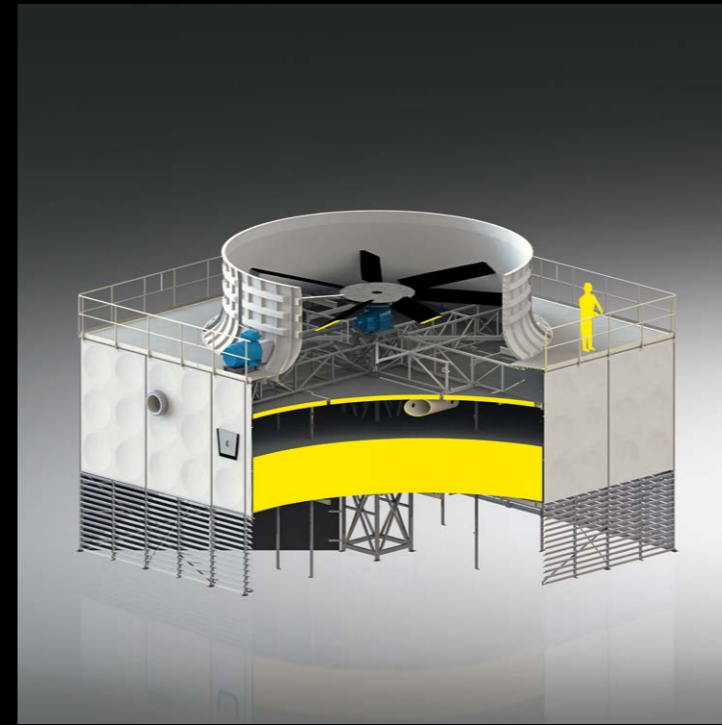

POLACEL CMDI COOLING TOWERS

Kelvion designs, manufactures and maintains cooling towers for process and climate cooling. Our energy-efficient and environmentally-friendly cooling water generators stand out because of the complete quality policy we employ.



The Polacel CMDI system concept can process large quantities of water and it has a substantial cooling capacity. The modules are supplied ready to use and they are easy to adjust to cooling requirements and the available space, whether they are used singly or in series. The cooling performance of these cooling towers is optimal and operation is problem free. With a 95%+ saving in water, the efficient CMDI systems are the best choice for man and his environment.

The Effect of Counterflow

CMDI cooling towers work on the principle of counterflow. This means that the water flows down while the air is pulled upwards by a fan. As the water flows further through the system, the air it encounters is fresher, in other words cooler and less saturated with moisture. Counterflow cooling towers can approach the wet bulb temperature better compared to crossflow cooling towers.

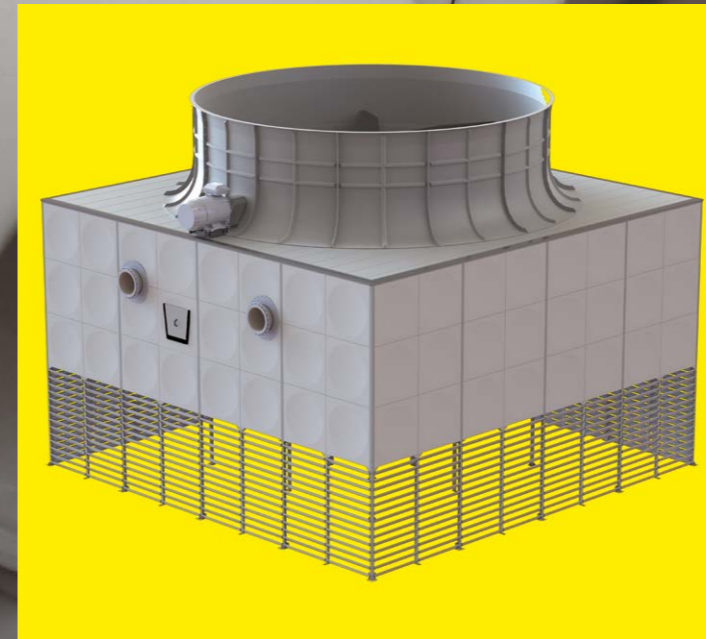
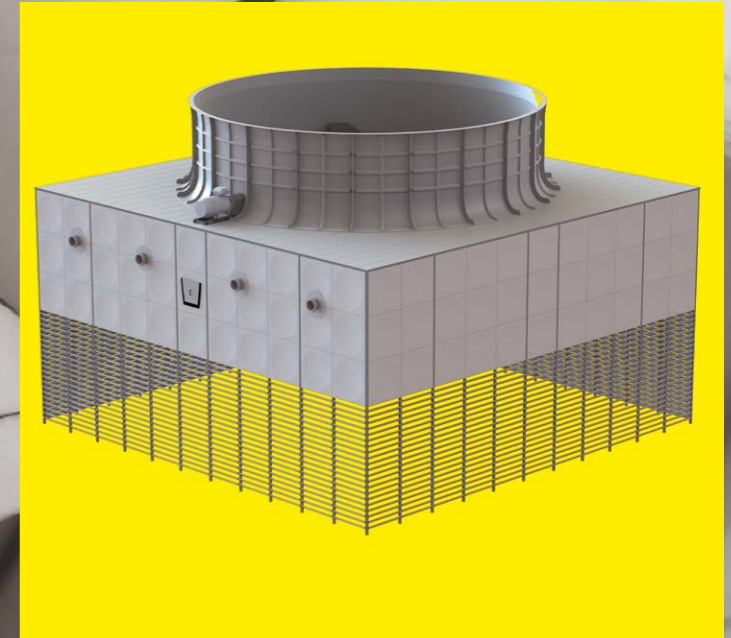



MODULES TO SIZE

The cooling water temperatures (inlet and outlet), the wet bulb temperature, noise and the water load are the four most important factors in the selection of a cooling tower.

Kelvion makes an inventory of the requirements together with the client and uses this inventory as the basis of the design for a suitable solution. The modular CMDI system can be extended, and there are standard solutions available for different capacity needs. Kelvion engineers make customized changes to meet special requirements.

Structural features

The advanced design engineering has also resulted in a number of special structural advantages:

- Only a minimum number of support points are necessary as a result of the self-supporting foundations and the high internal stiffness
- The Polacel CMDI system can be installed on existing water basins
- The extendable modular system offers flexible solutions in terms of form and capacity
- All structural design premises are analyzed and tested by means of dynamic calculations and computer studies beforehand



FAST AND FLEXIBLE CONSTRUCTION

Kelvion can build these cooling towers in a very limited time frame thanks to the structural quality and the flexible application options offered by the modular CMDI concept.

For example, the CMDI system can be assembled prior to a shutdown (alongside the existing operating cooling tower) and then be hoisted as a complete unit and installed on the existing water basin during the shutdown. This is why the construction time of a Polacel cooling tower always fits into your schedule.



Kelvion engineering

The CMDI design has a number of other special and exclusive features:

- The design of the fan section and the large fans ensure lower energy consumption and a substantial reduction in noise.
- Several types of fans can be selected depending on preference, environmental conditions and capacity.
- The water distribution system, the spray nozzles and the cooling modules can be geared to the water used and guarantee maximum contact with the air being drawn in.
- The air inlet louvres optimize the air inflow and minimize water losses through splashing
- Floating silencers minimize noise caused by falling water.
- Also available with polyester water basin.
- The designs take into account the desired variations in capacity, appropriate measures during maintenance and other user wishes.

NOISE REDUCTION

As a rule cooling towers are outdoors, and usually on a roof or at the edge of the site. The noise produced by the cooling tower caused by, among other things, the fan, falling water, the electrical motor or geared motor, can therefore present a problem. Kelvion has put a number of developments into practice that reduce the noise nuisance. Larger fans (lower speed, less noise and higher efficiency), floating silencers to reduce the noise of splashing and other noise reducing measures combat the different sources of noise. Kelvion provides a detailed picture of the nature and level of the noise produced by means of detailed calculations. Kelvion can also make calculations for all cooling towers beforehand in relation to the requirements laid down in environmental permits.

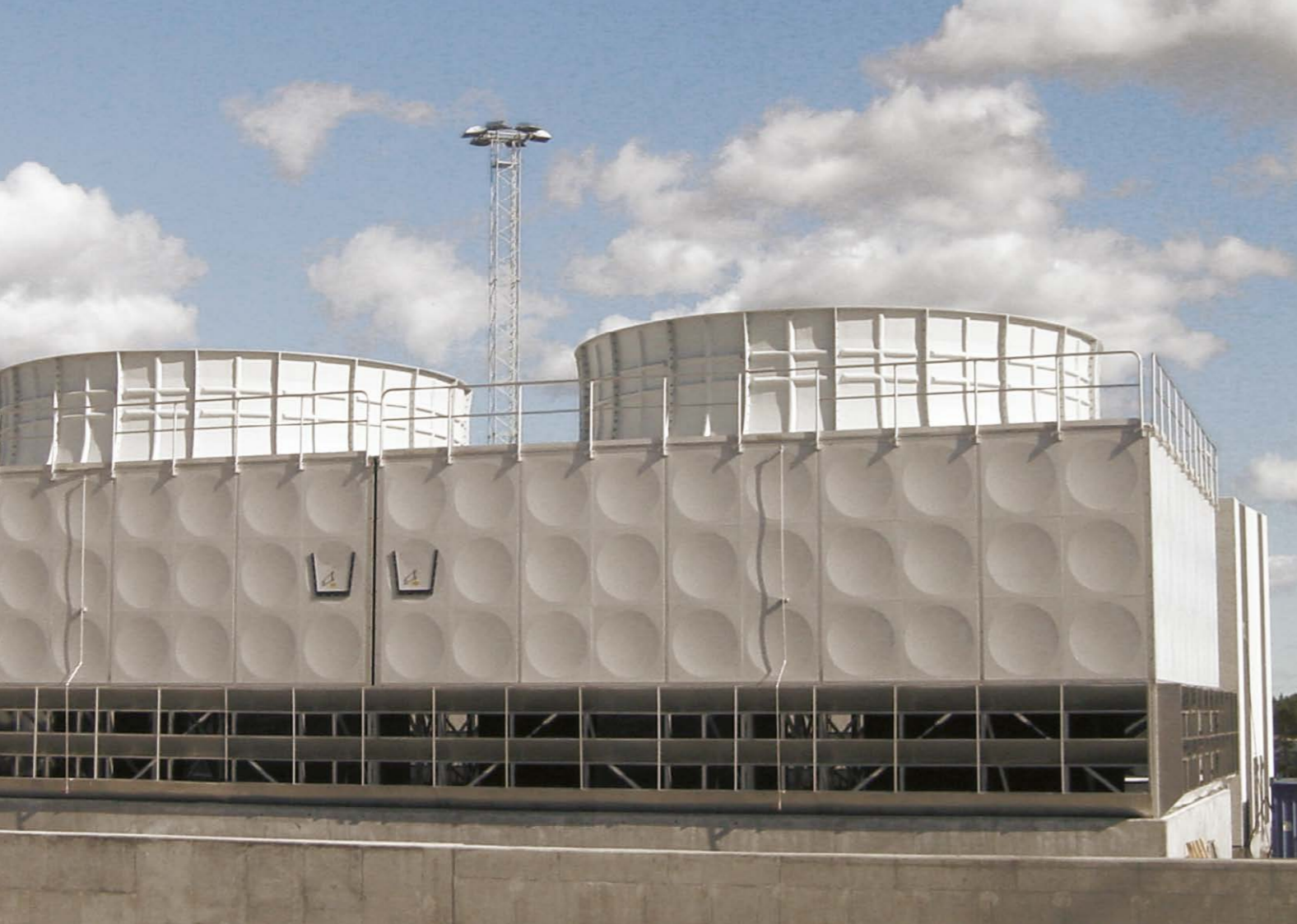

The security of quality

Kelvion designs and manufactures cooling towers with long lifetimes and minimal maintenance needs. This is achieved through the materials used - stainless steel combined with glass fibre and plastic - the sound design and the experience of our engineers. 'Cheap and cheerful' solutions, such as a fan with a V-belt drive or painted panels, are avoided. The result is a cooling tower that is low maintenance, energy efficient and able to supply constant excellent problem-free performance.



Advice and service

Kelvion builds cooling modules that meet precise specifications. Our sales engineers give advice, analyze your wishes and take personal responsibility for delivery so that your order is completely in line with your instructions. Kelvion's own service organization specializes in cooling tower maintenance. Irrespective of brand or version, the maintenance specialists know all the ins and outs of the whole technical area and are involved in the latest developments. Kelvion has broad experience in cooling tower maintenance. We work in accordance with the requirements described by ISO, VCA, VDMA, CTI and Eurovent. The technicians can carry out the maintenance needed in virtually every location and in practically any time frame.

